



Full Port Ball Valves without Schrader

TECHNICAL SPECIFICATIONS SUBMITTAL FORM

Job Name:	Submittal Date:	Wholesaler:
Job Location:	Engineer/Architect:	Contractor:

Product Use:

Full port ball valve for use in refrigeration, commercial HVAC, VRV, VRF, multi-mini split, and sub-critical applications.

Design and Features:

- Full port valves with 900 PSIG working pressure on sizes up to 7/8"
- Compatible with HCFC, HFC, HC, and HFO refrigerants and oils
- Rupture-proof encapsulated stem and bi-directional flow
- Two-piece stem cap
- One piece brass oven-brazed body
- 100% leak tested
- Stamped with serial number and packaged in poly-bag
- Two-year warranty

NBV Pressure Ratings and Weight

PART #	DESCRIPTION	MAXIMUM WORKING PRESSURE		WEIGHT	
		PSI	BAR	LB	KG
NBV02	1/4" Full Port Ball Valve	900	62	0.419	0.190
NBV03	3/8" Full Port Ball Valve	900	62	0.470	0.213
NBV04	1/2" Full Port Ball Valve	900	62	0.470	0.213
NBV05	5/8" Full Port Ball Valve	900	62	0.650	0.295
NBV06	3/4" Full Port Ball Valve	900	62	1.113	0.505
NBV07	7/8" Full Port Ball Valve	900	62	1.191	0.540
NBV09	1-1/8" Full Port Ball Valve	700	48	1.929	0.875
NBV11	1-3/8" Full Port Ball Valve	700	48	3.098	1.405
NBV13	1-5/8" Full Port Ball Valve	700	48	5.082	2.305
NBV17	2-1/8" Full Port Ball Valve	700	48	8.664	3.930
NBV21	2-5/8" Full Port Ball Valve	650	45	14.275	6.475
NBV25	3-1/8" Full Port Ball Valve	650	45	20.988	9.520
NBV33	4-1/8" Full Port Ball Valve	450	31	36.663	16.630



NBV Materials

PART	MATERIAL
STUBOUTS	Copper
SEALS & SEATS	Teflon (PTFE)
CAP	Brass
STEM	Stainless Steel
LOCK NUT	Brass, Stainless Steel
BODY	Brass
BALL	Stainless Steel



Full Port Ball Valves without Schrader

NBV Dimensions

MODEL	SIZE	D		L1		L2		L3		WEIGHT	
		MM	IN	MM	IN	MM	IN	MM	IN	LB	KG
NBV02	1/4"	6.40	0.25"	126.00	4.96"	53.00	2.09"	51.30	2.02"	0.419	0.190
NBV03	3/8"	9.58	0.38"	126.00	4.96"	53.00	2.09"	51.30	2.02"	0.470	0.213
NBV04	1/2"	12.75	0.50"	127.50	5.02"	54.00	2.13"	51.30	2.02"	0.470	0.213
NBV05	5/8"	15.93	0.63"	150.00	5.91"	63.30	2.57"	58.40	2.30"	0.650	0.295
NBV06	3/4"	19.10	0.75"	164.00	6.46"	74.00	2.91"	66.00	2.60"	1.113	0.505
NBV07	7/8"	22.28	0.88"	189.50	7.46"	86.00	3.39"	66.00	2.60"	1.191	0.540
NBV09	1-1/8"	28.65	1.13"	209.00	8.23"	97.00	3.82"	83.00	3.27"	1.929	0.875
NBV11	1-3/8"	35.00	1.38"	228.60	9.00"	109.00	4.29"	98.50	3.88"	3.098	1.405
NBV13	1-5/8"	41.35	1.63"	241.30	9.50"	115.00	4.53"	112.50	4.43"	5.082	2.305
NBV17	2-1/8"	54.05	2.13"	266.70	10.50"	131.00	5.16"	131.60	5.18"	8.664	3.930
NBV21	2-5/8"	66.75	2.63"	380.00	14.96"	184.00	7.24"	153.00	6.02"	14.275	6.475
NBV25	3-1/8"	79.45	3.13"	410.00	16.14"	198.00	7.80"	173.40	6.83"	20.988	9.520
NBV33	4-1/8"	104.85	4.13"	450.00	17.72"	221.00	8.70"	207.80	8.18"	36.663	16.630

Part Selection

NBV02	1/4" Full Port Ball Valve
NBV02BOX	1/4" Full Port Ball Valve Box Kit
NBV03	3/8" Full Port Ball Valve
NBV03BOX	3/8" Full Port Ball Valve Box Kit
NBV04	1/2" Full Port Ball Valve
NBV04BOX	1/2" Full Port Ball Valve Box Kit
NBV05	5/8" Full Port Ball Valve
NBV05BOX	5/8" Full Port Ball Valve Box Kit
NBV06	3/4" Full Port Ball Valve
NBV06BOX	3/4" Full Port Ball Valve Box Kit
NBV07	7/8" Full Port Ball Valve
NBV07BOX	7/8" Full Port Ball Valve Box Kit
NBV09	1-1/8" Full Port Ball Valve
NBV11	1-3/8" Full Port Ball Valve
NBV13	1-5/8" Full Port Ball Valve
NBV17	2-1/8" Full Port Ball Valve
NBV21	2-5/8" Full Port Ball Valve
NBV25	3-1/8" Full Port Ball Valve
NBV33	4-1/8" Full Port Ball Valve

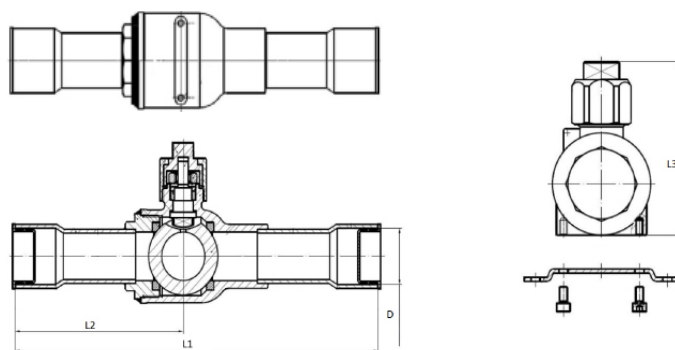

The information contained herein is not intended to replace the full product installation and safety information available or the experience of a trained product installer. You are required to thoroughly read all installation instructions and product safety information before beginning the installation of a product.

All installations must completely comply with all NDL Industries warnings and instructions, national state and local codes and all applicable ANSI standards.

NDL Industries product specifications in U.S. customary units and metric are approximate and are provided for reference only. For precise measurements, please contact Customer.

Service. NDL Industries reserves the right to change or modify product design, construction, specifications, or materials without prior notice and without incurring any obligation to make such changes and modifications on NDL products previously or subsequently sold.



Explore our full line of high-quality HVAC-R, CO₂ Refrigeration, and Hydronic products.

ndlindustries.com | 1-866-635-6888 | sales@ndlinc.com

@ndlindustries

