



NDL Industries

APPLICATIONS

Refrigeration, Commercial HVAC-R, VRV, VRF, Multi-mini Split, and Sub-critical Applications.

Mini-Split Reverse w/ Female Schrader (NBV-MSFFS)

NDL ball valves perform unlike any other in its class for leak prevention, reliability, and superior field performance.

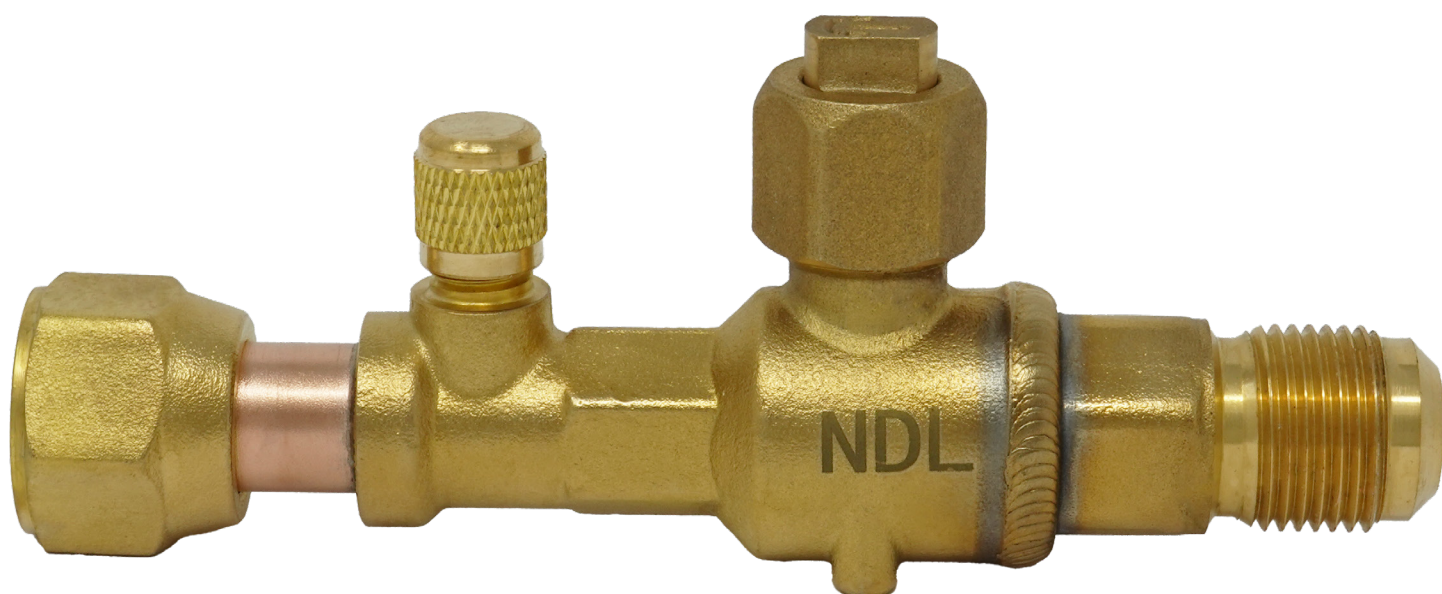

NBV-MSFFS Specifications

Quality Tested

Tested with 95% nitrogen and 5% hydrogen solution at 450 PSIG to detect and correct any leaks before leaving the factory.

Teflon Seals and Seats

Reduce service calls, refrigerant loss, and environmental contamination with our cone-shaped 100% virgin Teflon seals and seats that will not shrink or leak, eliminating seal replacement during changeovers.

Bottom-Up Stem Installation

Our stem placement is engineered from the bottom up. If there is an accidental over-pressurization in the valve, it will not blow the stem out and lose the charge. Plus, using the virgin Teflon seals ensures no need for seal replacement.

Two-Piece Cap Nut

No need to remove the cap during installation or service. Loosen the nut, turn 1/4 of the stem cap, and open the valve fully; close by turning 1/4 again. Tighten the nut, and the job is complete.

Oven-brazed Construction

Joined together with a smooth and equal brazing process to prevent pinhole leaks.

Unparalleled Two-year Warranty

Our warranty proves confidence, along with proudly stamping every valve with a serial number and cleanly packaging in a poly-bag to prevent contamination and malfunctions.

Heavy-duty Full Port Valves

Built to last with 900 PSIG working pressure on sizes up to 7/8".



NBV-MSFFS Mini-Split Reverse Ball Valves

NBV-MSFFS Certifications and Approvals

- UL/cUL 207 (up to 1-1/8")
- RoHS Compliant
- CRN-approved
- CE-approved

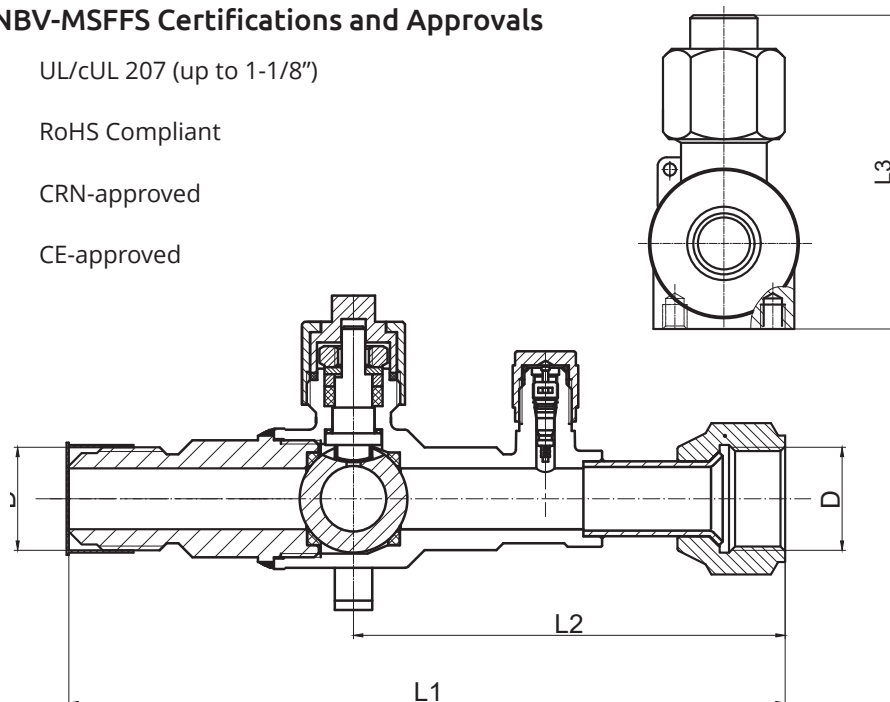

NBV-IN Insulation

EPDM-based, closed cell, light-weight elastomeric thermal insulation for temperatures up to 150°C (302°F).

- Tough skin for easy installation
- Self-extinguished and does not melt when burned
- Indoor and outdoor use
- NBV-IN-S: compatible with 1/4" to 5/8" ball valves with Schrader
- NBV-IN-M: compatible with 3/4" to 7/8" ball valves with Schrader

NBV-MSFFS Dimensions

MODEL	SIZE	MAXIMUM WORKING PRESSURE		D	L1		L2		L3		WEIGHT	
		PSI	BAR		MM	IN	MM	IN	MM	IN	LB	G
NBV14MSFFS	1/4"	900	62	7/16-20" UNF	125.00	4.92"	80.00	3.15"	51.30	2.02"	0.507	230
NBV38MSFFS	3/8"	900	62	5/8-18" UNF	122.00	4.80"	71.00	2.80"	51.30	2.02"	0.595	270
NBV12MSFFS	1/2"	900	62	3/4-16" UNF	153.00	6.02"	102.00	4.02"	51.30	2.02"	0.628	285
NBV58MSFFS	5/8"	900	62	7/8-14" UNF	153.00	6.02"	92.20	3.63"	58.40	2.30"	0.948	430



Explore our full line of high-quality HVAC-R, CO₂ Refrigeration, and Hydronic products.

ndlindustries.com | 1-866-635-6888 | sales@ndlinc.com

@ndlindustries

